

Valve Type	ASME Class	HYDROSTATIC								AIR		ASME Class	Working Pressure (in psi)			
		Shell		Back Seat		Seat Closure				Seat			F5,F9 F11,F22	F304, F316, F321, F347	F304L, F316L	
		psi	kg/cm ²	psi	kg/cm ²	High Pressure		Low Pressure		psi	kg/cm ²					
Gate	150	450	32	315	22	-	-	-	-	90	6.3	150	Shell	450	425	350
	300	1125	79	815	57	-	-	-	-	90	6.3		Seat	320	305	255
	600	2225	156	1630	115	-	-	-	-	90	6.3	300	Shell	1125	1100	900
	800	3000	211	2200	155	-	-	-	-	90	6.3		Seat	825	795	660
	1500	5575	392	4080	287	-	-	-	-	90	6.3		Shell	2250	2175	1800
Globe	150	450	32	315	22	315	22	-	-	90	6.3	600	Shell	2250	2175	1800
	300	1125	79	815	57	815	57	-	-	90	6.3		Seat	1650	1585	1320
	600	2225	156	1630	115	1630	115	-	-	90	6.3	800	Shell	3000	2900	2400
	800	3000	211	2200	155	2200	155	-	-	90	6.3		Seat	2200	2115	1760
Check	150	450	32	-	-	315	22	80	6	-	-	1500	Shell	5625	5400	4500
	300	1125	79	-	-	815	57	210	15	-	-		Seat	4125	3960	3300
	600	2225	156	-	-	1630	115	410	29	-	-					
	800	3000	211	-	-	2200	155	550	39	-	-					
B'Sealed Gate	800	3000	211	2200	155	-	-	-	-	90	6.3					
B'Sealed Globe	800	3000	211	2200	155	2200	155	-	-	90	6.3					

* Test pressure values are for ASTM A105 and LF2 materials of construction. For other materials, substitute corresponding figures from the table alongside. For check valves, low pressure hydrostatic closure test is carried out at 25% of the high pressure closure test.

Compliance Standards

Valve Type	Valve Design	Face-to-face dimension	End Connection	Pressure / Temp. rating**	Valve inspection and testing	
Gate Valves	API 602* BS 5352	AIL Standard (screwed/socket-weld/ butt-weld) ASME B16.10 BS 2080 (flanged)	ASME B1.20.1 (NPT) BS 21 / ISO 7 (screwed - taper)	API 602 ASME B16.34	API 598 BS 5352	
Globe and Check Valves	BS 5352*		BS 2779 / ISO 228• BS 21 / ISO 7 (screwed - parallel)	ASME B16.11 (socket-weld)	BS 5352 ASME B16.34	API 598 BS 5352
Cryo Gate & Globe Valves	BS 6364		ASME B16.5RF 125-250 Ra (flanged)	ASME B16.11	BS 6364	BS 6364 API 598 BS 5352
Y-Globe and Check Valves	ASME B16.34 MSS SP 84	AIL Standard	see page 10	ASME 16.34	API 598	

For Class 150 valves, the flange drilling dimensions will be as per Class 150 and all other dimensions as per Class 300. End flanges are welded onto the body.

Bellows-Sealed Gate and Globe valves conform to BS 5352.

Socket-weld Class 800 Reduced Bore valves conform to Class 3000 (or Sch.80/Sch.XS) fittings of ASME B16.11.

Socket-weld Class 800 Full Bore valves conform to Class 6000 (or Sch.160) fittings of ASME B16.11.

Socket-weld Class 1500 Standard Port valves conform to Class 9000 (or Sch.XXS) fittings of ASME B16.11.

*Full Bore design also conforms to ASME B16.34 ** API 602/BS 5352 for Class 800 and ASME B16.34 for Class 150/300/600/1500/2500

Ordering Information - Straight-pattern Valves

Size	Valve Type	Pressure Class	End Connection	Trim	Body Material	Options
1/4"	2 - Gate 5 - Globe 8 - Check	1 - Class 150	1 - Screwed NPT	01- 13% Cr.	NIL- A105 LF2 F5 F11 F22 F304 / F304L F316 / F316L F347 Monel	NIL - Reduced / Standard Bore FB - Full Bore WB - Welded Bonnet LA - Locking Arrangement E - Electrical Actuator BS - Bellows-Sealed CR - Cryogenic
3/8"		3 - Class 300	2 - Socket-weld	05- HF		
1/2"		5 - Class 1500	3 - Flanged	08- 13% Cr. HF		
3/4"		6 - Class 600	4 - Screwed BSP parallel	API Trim Nos. 10, 12, etc., also available		
1"		8 - Class 800	5 - Screwed BSP taper			
1 1/4"						
1 1/2"						
2"						

Ordering Information - Y-pattern Valves

Size	Valve type	Pressure Class	End Connection	Trim	Body material	Options
15- 15mm	6 - Scr. Bonnet 7 - Seal-welded Bonnet	15- Class 1500	3 - Butt-weld	U- Hardfaced seating surface	NIL- A105 F316 F11 F316L F22 F347	NIL - Standard IBR - IBR-certified
20- 20mm		25- Class 2500	4 - Screwed NPT			
25- 25mm			5 - Socket-weld			
40- 40mm	8 - Scr. Cap 9 - Seal-welded Cap					
50- 50mm						

Familiarity with our catalogue numbering is not necessary when specifying or ordering our valves. A full description of the valve provided by you is translated into a catalogue number as per the system shown.

For any other special requirement, add SPL to the catalogue number and provide details.

Straight-pattern Gate/Globe/Check V alves

Salient features

- Bolted body-bonnet design for valves up to Class 800. Valves with welded bonnet also available on request
- Screwed with seal-welded body-bonnet design for valves of Class 1500
- Bellows-sealed Gate and Globe valves available in Class 800
- Bolted body-bonnet joints provided with spiral-wound stainless steel gasket and graphite filler for maximum protection against leaks
- Die-formed graphite inner packing rings and braided graphite end rings with Inconel wire reinforcement and corrosion inhibitor
- T-head stem-disc connection of gate valve fully meets strength requirements of API 602 and API 598
- Rolled ACME thread on stem for smooth operation
- Tapered shoulder on the stem for back seating
- Self-aligning type gland assembly with stud-and-nut tightening
- Integral hard-faced body seat for globe and check valves
- Spring-loaded disc on check valves suitable for non-horizontal applications too
- Gate and globe valves can be offered with electrical actuators
- Austenitic SS forging for body and bonnet of Cryogenic valves, resulting in excellent impact strength, minimal heat loss and resistance to corrosion
- Valves can be offered to NACE MR-0175 and other special NACE requirements
- Valves can be supplied with IBR certification



Body and Trim Combinations

Body&Bonnet/Cover	Trim numbers
ASTM A10501	/ 08 / 05
ASTM A182 Gr. F508	/ 05
ASTM A182 Gr. F9	08 / 05
ASTM A182 Gr. F11	08 / 05
ASTM A182 Gr. F22	08 / 05
ASTM A182 Gr. F304	02 / 15
ASTM A182 Gr. F316	10 / 12 / 16
ASTM A350 Gr. LF2	08 / 16

Other materials of construction such as F316L/ F304L also available.

Trim Materials

AIL Forged Steel Valves are offered with trims shown below, to suit a variety of services.

Trim No. (API 602)	Valve Type	Stem Material	Seating Surfaces	
			Disc	Body Seat
01	Gate Valves	ASTM A479 Type 410	13% Cr. Steel	13% Cr. Steel
05Gate,	Globe and Check Valves	ASTM A479 Type 410	HF	HF
08	Gate, Globe and Check Valves	ASTM A479 Type 410	13% Cr. Steel	HF
02	Gate Valves	ASTM A479 Type 304	SS 304	SS 304
10	Gate Valves	ASTM A479 Type 316	SS 316	SS 316
12	Gate, Globe and Check Valves	ASTM A479 Type 316	SS 316	HF
15Gate,	Globe and Check Valves	ASTM A479 Type 304	SS 304	HF HF
16	Gate, Globe and Check Valves	ASTM A479 Type 316	SS 316 + HF	HF

HF - Hard Faced with Cobalt-Chromium-Tungsten alloy (Stellite #6)

Gate Valves

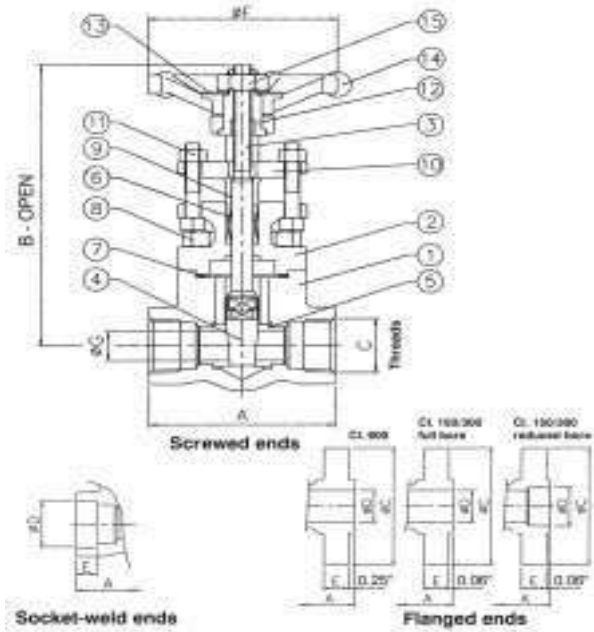

Material Specification (Typical for Fig No. 28101)

Sl. No.	Part Description	Specification
1	Body	ASTM A105
2	Bonnet	ASTM A105
3	Stem	ASTM A479 Type 410
4	Wedge Disc	ASTM A217 Gr. CA15
5	BodySeatRing	ASTMA276Type 410
6	Stem packing	Graphite moulded rings with braided top / bottom rings
7	Gasket	Spiral-wound SS type 304 with graphite filler
8	Cap Screws	ASTM A193 Gr. B7
9	Gland Bush	ASTM A276 Type 410
10	Gland Flange	ASTM A105
11	Gland Stud / Nut	ASTM A276 Type 410 / ASTM A194 Gr. 2H
12	Yoke Sleeve	ASTM A582 Type 416
13	Identification Plate	Aluminium (anodised)
14	Handwheel	SG Iron / Steel
15	Handwheel Nut	Steel

Screwed/Socket-weld ends (in inches, unless specified)

Class 800

Valve size inch (mm)	CLASS 800 GATE VALVES												
	A	B		C		D (min)	E	F		G		App. Wt. (kg)	
		RB	FB	RB	FB			RB	FB	RB	FB	RB	FB
1/4 (8)**	3.156	0	-	1/4	-	0.555	0.38	3.25	-	0.25	-	1.6	-
3/8 (10)	3.156	0	6.0	3/8	-	0.690	0.38	3.25	3.25	0.38	1.6	1.6	-
1/2 (15)	3.15	6.0	6.2	1/2	-	0.855	0.38	3.25	3.25	0.38	0.50	1.6	2.0
3/4 (20)	3.356	2	7.5	3/4	-	1.065	0.50	3.25	4.00	0.50	0.71	2.0	3.1
1 (25)	3.94	7.5	10.0	1	-	1.330	0.50	4.00	5.50	0.71	0.94	3.1	6.1
1 1/4 (32)	4.70	10.0	10.0	1 1/4	-	1.675	0.50	5.50	5.50	0.94	1.19	6.1	6.0
1 1/2 (40)	4.70	10.0	11.4	1 1/2	-	1.915	0.50	5.50	7.25	1.19	1.44	6.0	9.1
2 (50)**	5.12	11.4	-	2	-	2.406	0.62	7.25	1.44	-	9.1	-	-

Flanged ends (in inches, unless specified)

Class 600

Valve size inch (mm)	CLASS 600 GATE VALVES											
	A	B		C	ø D		E	ø F		App. Wt. (kg)		
		RB	FB		RB	FB		RB	FB	RB	FB	
1/2 (15)	6.5	6.0	6.2	3.75	0.50	0.62	0.56	3.25	3.25	3.5	5.1	
3/4 (20)	7.56	2	7.54	6.2	0.75	0.82	0.62	3.25	4.00	1.15	7.1	
1 (25)	8.5	7.5	10.0	4.88	1.00	1.05	0.69	4.00	5.50	7.1	11.3	
1 1/4 (32)	9.0	10.0	10.0	5.25	1.25	1.38	0.81	5.50	5.50	11.3	13.5	
1 1/2 (40)	9.5	10.0	11.4	6.12	1.50	1.61	0.88	5.50	7.25	13.5	19.2	
2 (50)	11.5	11.4	-	6.50	2.00	-	1.00	7.25	-	19.2	-	

Flanged ends (in inches, unless specified)

Class 150/300

Valve size inch (mm)	CLASS 150 / 300 GATE VALVES									
	A	B		C		ø D	E	ø F		
		RB	FB	Class 150	Class 300			RB	FB	
1/2 (15)	5.5	6.0	6.2	3.50	3.75	0.62	0.56	3.25	3.25	
3/4 (20)	6.0	6.2	7.53	3.88	4.62	0.82	0.62	4.25	4.25	
1 (25)	6.5	7.5	10.0	4.25	4.88	1.05	0.69	4.00	5.50	
1 1/4 (32)	7.0	10.0	10.0	4.62	5.25	1.38	0.75	5.50	5.50	
1 1/2 (40)	7.5	10.0	11.4	5.00	6.12	1.61	0.81	5.50	7.25	
2 (50)	8.5	11.4	-	6.00	6.50	2.07	0.88	7.25	-	

All Straight-pattern Valves

Gate Valves

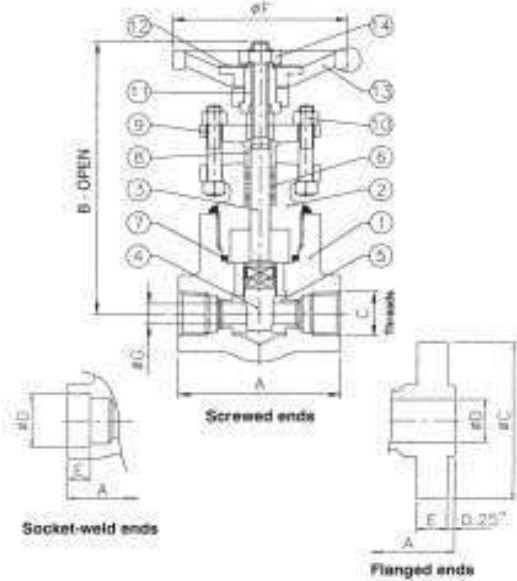

Material Specification (Typical for Fig No. 25101)

Sl. No.	Part Description	Specification
1	Body	ASTM A105
2	Bonnet	ASTM A105
3	Stem	ASTM A479 Type 410
4	Wedge Disc	ASTM A217 Gr. CA15
5	Body Seat Ring	ASTM A276 Type 410
6	Gasket	Spiral-wound SS type 304 with graphite filler
7	Stem packing	Graphite moulded rings with braided top/bottom rings
8	Gland Bush	ASTM A276 Type 410
9	Gland Flange	ASTM A105
10	Gland Stud / Nut	ASTM A276 Type 410 / ASTM A194 Gr. 2H
11	Yoke Sleeve	ASTM A582 Type 416
12	Identification Plate	Aluminium (anodised)
13	Handwheel	SG Iron / Steel
14	Handwheel Nut	Steel

Class 1500 Standard Port (in inches)

Valve size inch (mm)	SCREWED / SOCKET -WELD ENDS							FLANGE ENDS						
	A	B	C	D (min)	E	F	G	A	B	C	D	E	F	G
3/8 (10)	3.70	7.32	3/8	0.690	0.38	4.00	0.250	-	-	-	-	-	-	-
1/2 (15)	3.70	7.32	1/2	0.805	0.38	4.00	0.375	5.82	4.75	0.5	0.88	4.00	0.375	
3/4 (20)	3.70	7.32	3/4	1.065	0.50	4.00	0.500	9.00	7.32	5.12	0.75	1.00	4.00	0.500
1 (25)	4.40	7.50	1	1.330	0.50	5.50	0.625	10.00	7.50	5.88	1.00	1.12	5.50	0.625
1 1/4 (32)	5.12	10.92	1 1/4	1.675	0.57	7.25	1.102	11.00	10.92	6.25	1.12	7.25	1.102	
1 1/2 (40)	5.12	10.92	1 1/2	1.915	0.50	7.25	1.102	12.00	10.92	7.00	1.50	1.25	7.25	1.102
2 (50)	7.82	19.10	2	2.406	0.62	14.00	1.500	14.50	19.10	8.50	2.00	1.50	14.00	1.500

For weights, refer to ALL.

Bellows-Sealed Gate and Globe V valves

Class 800 - Reduced Bore and Full Bore (for dimensions, refer to ALL)

Material Specification (Standard)

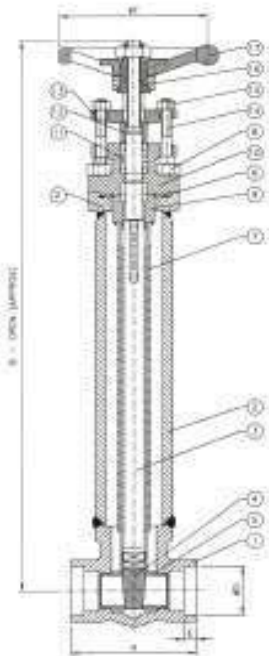

Sl. No.	Part Description	Specification
1	Body	ASTM A105, in-situ stellite seat
2	Pipe (top/bottom)	ASTM A105
3	Stem	ASTM A479 Type 316
4	Disc	ASTM A351 Gr. CF8M, seat face stellite
5	Seat Ring	ASTM A276 Type 316, seat face stellite
6	Gasket	Spiral-wound SS 316 with graphite filler
7	Bellows	SS 316L
8	Cap Screw	ASTM A193 Gr. B7
9	Guide	ASTM A276 Type 316
10	Bonnet	ASTM A105
11	Packing	Graphite rings with braided end rings
12	Gland	ASTM A276 Type 316
13	Gland Flange	ASTM A105
14	Stud	ASTM A276 Type 410
15	Nut	ASTM A194 Gr. 2H
16	Yoke Sleeve	ASTM A582 Type 416
17	Handwheel	SG Iron / Mall. Iron
18	Plug (1/16 NPT)	Carbon Steel

Note : Valves are available with screwed and socket-weld ends.
For dimensions, refer to ALL.

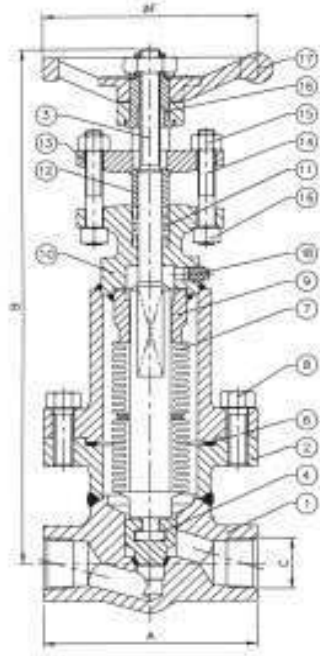

Globe Valves

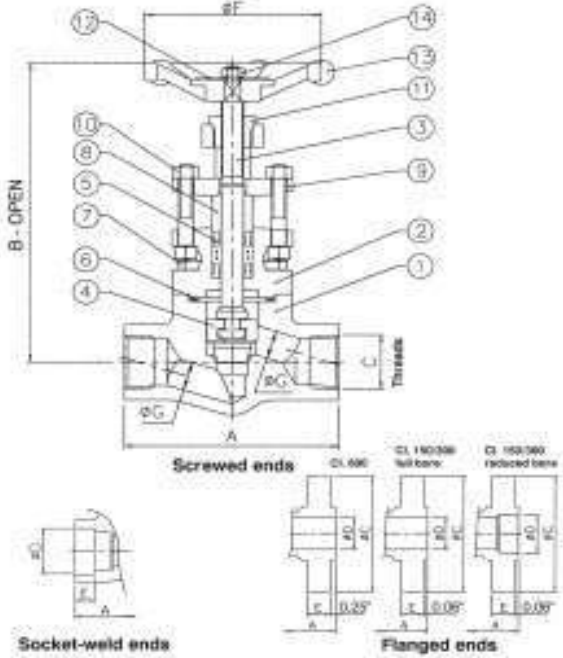

Material Specification (Typical for Fig No. 58108)

Sl. No.	Part Description	Specification
1	Body	ASTM A105, in-situ stellite seat
2	Bonnet	ASTM A105
3	Stem	ASTM A479 Type 410
4	Plug Disc	ASTM A217 Gr. CA15
5	Stem packing	Graphite moulded rings with braided top / bottom rings
6	Gasket	Spiral-wound SS type 304 with graphite filler
7	Cap Screws	ASTM A193 Gr. B7
8	Gland Bush	ASTM A276 Type 410
9	Gland Flange	ASTM A105
10	Gland Stud / Nut	ASTM A276 Type 410 / ASTM A194 Gr. 2H
11	Yoke Bush	ASTM A582 Type 416
12	Identification Plate	Aluminium (anodised)
13	Handwheel	SG Iron / Steel
14	Handwheel Nut	Steel

Screwed/Socket-weld ends (in inches, unless specified)

Class 800

Valve size inch (mm)	C L A S S 8 0 0 G L O B E V A L V E S												App. Wt. (kg)	
	A	B		C		D (min)	E	F		G		RB	FB	
		RB	FB	RB	FB			RB	FB	RB	FB			
1/4 (8)	3.20	5.8	-	1/4	-	0.555	0.38	3.25	-	0.25	-	1.7	-	
3/8 (10)	3.20	5.8	5.8	3/8		0.690	0.38	3.25	2.50	0.38	1.7	1.7		
1/2 (15)	3.20	5.8	6.4	1/2		0.855	0.38	3.25	4.00	0.38	0.50	1.7	2.4	
3/4 (20)	4.00	6.4	7.7	3/4		1.065	0.50	4.00	4.00	0.50	0.69	2.4	3.6	
1 (25)	4.85	7.7	9.6	1		1.330	0.50	4.00	5.50	0.69	0.94	3.6	6.8	
1 1/4 (32)	6.40	9.6	9.6	1 1/4		1.675	0.50	5.50	5.50	0.94	1.17	6.8	6.7	
1 1/2 (40)	6.40	9.6	11.6	1 1/2		1.915	0.50	5.50	7.25	1.17	1.44	6.7	10.8	
2 (50)	8.80	11.6	-	2	-	2.406	0.62	7.25	-	1.44	-	10.8	-	

Flanged ends (in inches, unless specified)

Class 600

Valve size inch (mm)	C L A S S 6 0 0 G L O B E V A L V E S												App. Wt. (kg)	
	A		B		C	ø D		E	ø F		RB	FB		
	RB	FB	RB	FB		RB	FB		RB	FB				
1/2 (15)	6.5	6.5	5.8	6.4	3.75	0.50	0.62	0.56	3.25	4.00	3.6	5.4		
3/4 (20)	7.57	5.64	7.7	4.62	0.750	0.82	0.62	4.00	4.00	0.45	7.4			
1 (25)	8.5	8.5	7.7	9.6	4.88	1.00	1.05	0.69	4.00	5.50	7.4	11.4		
1 1/4 (32)	9.0	9.0	9.6	9.6	5.25	1.25	1.38	0.81	5.50	5.50	11.4	13.5		
1 1/2 (40)	9.5	11.5*	9.6	11.6	6.12	1.50	1.61	0.88	5.50	7.25	13.5	19.1		
2 (50)	11.5	-	11.6	-	6.50	2.00	-	1.00	7.25	-	19.1	-		

* Greater than ASME B16.10 / BS 2080

Flanged ends (in inches, unless specified)

Class 150/300

Valve size inch (mm)	C L A S S 1 5 0 / 3 0 0 G L O B E V A L V E S											
	A		B		C		ø D	E	ø F			
	RB	FB	RB	FB	Class 150	Class 300			RB	FB		
1/2 (15)	6.0	6.0	5.80	6.35	3.50	3.75	0.62	0.56	3.25	4.00		
3/4 (20)	7.0	7.0	6.35	7.0	3.88	4.62	0.82	0.62	4.00	4.00		
1 (25)	8.0	8.0	7.70	9.55	4.25	4.88	1.05	0.69	4.00	5.50		
1 1/4 (32)	8.5	8.5	9.55	9.55	4.62	5.25	1.38	0.75	5.50	5.50		
1 1/2 (40)	9.0	11.5*	9.55	11.60	5.00	6.12	1.61	0.81	5.50	7.25		
ø (50.5-)	11.60	-	6.00		0.65	2.07	0.88	7.25-				

* Greater than ASME B16.10 / BS 2080

ALL Straight-pattern Valves

Check V alves

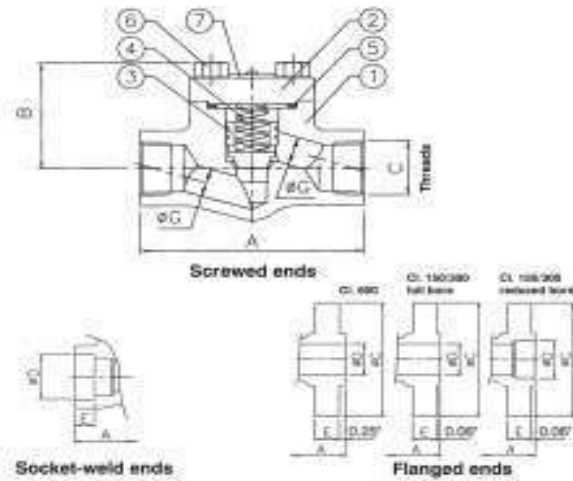

Material Specification (Typical for Fig No. 88108)

Sl. No.	Part Description	Specification
1	Body	ASTM A105, in-situ stellite seat
2	Cover	ASTM A105
3	Piston Disc	ASTM A276 Type 410
4	Spring	SS 302
5	Gasket	Spiral-wound SS type 304 with graphite filler
6	Cap Screws	ASTM A193 Gr. B7
7	Identification Plate	Aluminium (anodised)

Minimum differential pressure of 1 bar required for operating the valve.

Screwed/Socket-weld ends (in inches, unless specified)

Valve size inch (mm)	C L A S S 8 0 0 C H E C K V A L V E S										
	A		B		C	D (min)	E	G		App. Wt. (kg)	
	RB	FB	RB	FB				RB	FB	RB	FB
1/4 (8)	3.20	-	2.1	-	1/4	0.555	0.38	0.25	-	1.1	-
3/8 (10)	3.20	3.20	2.1	2.1	3/8	0.690	0.38	0.25	0.38	1.1	1.1
1/2 (15)	3.20	4.00	2.1	2.3	1/2	0.855	0.38	0.38	0.50	1.1	1.5
3/4 (20)	4.00	4.85	2.3	2.6	3/4	1.065	0.50	0.50	0.69	1.5	2.4
1 (25)	4.85	6.40	2.6	3.5	1	1.330	0.50	0.69	0.94	2.4	4.4
1 1/4 (32)	6.40	6.40	3.5	3.5	1 1/4	1.675	0.5	0.94	1.17	4.4	4.4
1 1/2 (40)	6.40	8.80	3.5	4.1	1 1/2	1.915	0.5	1.17	1.44	4.3	6.8
2 (50)	8.80	-	4.1	-	2	2.406	0.62	1.44	-	6.8	-

Class 800

Flanged ends (in inches, unless specified)

Valve size inch (mm)	C L A S S 6 0 0 C H E C K V A L V E S										
	A		B		C	ø D		E	App. Wt. (kg)		
	RB	FB	RB	FB		RB	FB		RB	FB	
1/2 (15)	6.5	6.5	2.1	2.3	3.75	0.50	0.62	0.56	3.0	4.6	
3/4 (20)	7.57	7.57	2.6	2.6	4.62	0.75	0.82	0.62	4.6	6.2	
1 (25)	8.5	8.5	2.6	3.5	4.88	1.00	1.05	0.69	6.2	9.1	
1 1/4 (32)	9.0	9.0	3.5	3.5	5.125	1.38	0.81	9.1	11.2		
1 1/2 (40)	9.5	11.5*	3.5	4.1	6.12	1.50	1.61	0.88	11.2	15.2	
2 (50)	11.5	-	4.1	-	6.50	2.00	-	1.00	15.2	-	

Class 600

* Greater than ASME B16.10 / BS 2080

Flanged ends (in inches, unless specified)

Valve size inch (mm)	C L A S S 1 5 0 / 3 0 0 C H E C K V A L V E S							
	A		B		C		ø D	E
	RB	FB	RB	FB	Class 150	Class 300		
1/2 (15)	6.0	6.0	2.10	2.30	3.50	3.75	0.62	0.56
3/4 (20)	7.0	7.0	2.30	2.60	3.88	4.62	0.82	0.62
1 (25)	8.0	8.0	2.60	3.50	4.25	4.88	1.05	0.69
1 1/4 (32)	8.5	8.5	3.50	3.50	4.62	5.25	1.38	0.75
1 1/2 (40)	9.0	11.5*	3.50	4.10	5.00	6.12	1.61	0.81
2 (50)	10.5	-	4.10	-	6.00	6.50	2.07	0.88

Class 150/300

* Greater than ASME B16.10 / BS 2080

Cryogenic Gate V alves

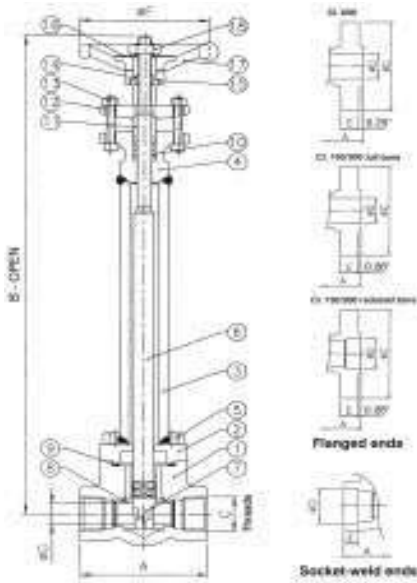

Material Specification (Standard)

Sl. No.	Part Description	Specification
1	Body	ASTM A182 Gr. F304/F316
2	Cover Flange	ASTM A182 Gr. F304/F316
3	Extension Column	ASTM A312 Gr. TP304L/316L
4	Bonnet	ASTM A182 Gr. F304/F316
5	Cap Screw	ASTM A320 Gr. B8 Cl. 2
6	Stem	ASTM A479 Gr. 304/316
7	Wedge Disc	ASTM A351 Gr. CF8/CF8M with suitable seating surface
8	Body Seat Ring	Type 304/316 with suitable seating surface
9	Gasket	Spiral-wound SS type 304 with graphite filler
10	Stem packing	Graphite moulded rings with braided top/bottom rings
11	Gland Bush	Type 304/316 SS
12	Gland Flange	ASTM A182 Gr. F304/F316
13	Gland, Stud and Nut	ASTM A320 Gr. B8 Cl. 2 / ASTM A194 Gr. 8
14	Yoke Sleeve	Type 416 SS
15	Thrust Washer	Sintered Bronze/SS-backed PTFE / CS-backed PTFE
16	Identification Plate	Aluminium (anodised)
17	Handwheel	SG Iron / Steel
18	Handwheel Nut	Steel

Cryogenic Globe V alves

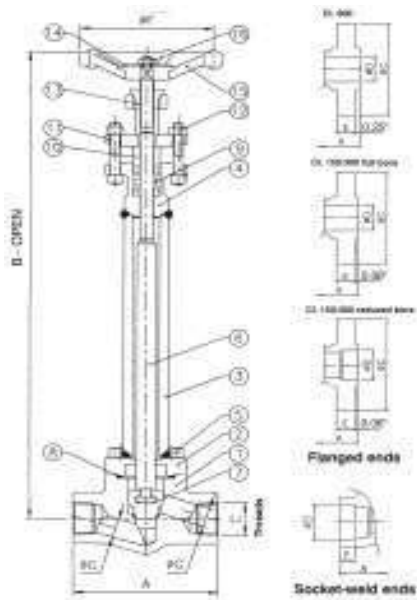

Material Specification (Standard)

Sl. No.	Part Description	Specification
1	Body	ASTM A182 Gr. F304/F316, in-situ stellite seat
2	Cover Flange	ASTM A182 Gr. F304/F316
3	Extension Column	ASTM A312 Gr. TP304L/316L
4	Bonnet	ASTM A182 Gr. F304/F316
5	Cap Screw	ASTM A320 Gr. B8 Cl. 2
6	Stem	ASTM A479 Gr. 304/316
7	Plug Disc	ASTM A351 Gr. CF8/CF8M with suitable seating surface
8	Gasket	Spiral-wound SS type 304 with graphite filler
9	Stem packing	Graphite moulded rings with braided top/bottom rings
10	Gland Bush	Type 304/316 SS
11	Gland Flange	ASTM A182 Gr. F304/F316
12	Gland, Stud and Nut	ASTM A320 Gr. B8 Cl. 2 / ASTM A194 Gr. 8
13	Yoke Bush	Type 416 SS
14	Identification Plate	Aluminium (anodised)
15	Handwheel	SG Iron / Steel
16	Handwheel Nut	Steel

Class 800 Screwed/Socket-weld ends (in inches, unless specified)

Valve size inch (mm)	CLASS 800 CRYO GATE / GLOBE VALVES																	
	A		B				C	D (min)	E	GATE				GLOBE				
	GLOBE		GATE		GLOBE					F		G		F		G		
	GATE	RB	FB	RB	FB	RB	FB	RB	FB	RB	FB	RB	FB	RB	FB			
1/2 (15)	3.94	3.20	4.00	17.1	17.1	16.2	16.7	1/2	0.688	3.25	3.38	0.5	3.25	4.00	0.38	0.5		
3/4 (20)	3.94	4.00	4.85	17.1	17.1	16.7	17.0	3/4	1.065	0.50	3.25	4.00	0.50	0.71	4.00	4.00	0.50	0.69
1 (25)	3.94	4.85	6.40	17.1	20.7	17.0	20.0	1	1.330	0.50	4.00	5.50	0.71	0.94	4.00	5.50	0.69	0.94
1 1/4 (32)	4.70	6.40	6.40	20.7	20.7	20.0	20.0	1 1/4	1.675	0.50	5.50	5.50	0.94	1.19	5.50	5.50	0.94	1.17
1 1/2 (40)	4.70	6.40	8.80	20.7	22.1	20.0	21.8	1 1/2	1.915	0.50	5.50	7.25	1.19	1.44	5.50	7.25	1.17	1.44
20.1 (2580)	-	-	22.1	-	21.8	-	2	2.406	0.62	7.25	-	1.44	-	7.25	-	1.44	-	-

Cryogenic valves are also available in Class 150, 300, 600 and 1500, with dimensions generally as per corresponding gate/globe valves in pages 5 - 7. For detailed dimensions, refer to AIL.